



DEEP SEA ELECTRONICS

701HC

MANUAL START
WITH INTEGRAL
HOURS COUNTER

Issue 1
MR 03/01/03

DESCRIPTION

The Model 701HC is a **Manual Engine Control Module** designed to control the engine via a key switch and pushbuttons on the front panel. The module is used to start and stop the engine and indicate fault conditions, automatically shutting down the engine and indicating the engine failure by LED, giving true, first-up fault annunciation. An integral anti-tamper LCD hours run counter is also provided.

Operation of the module:

1. Select manual run (M)
2. Press pre-heat button (V) for required length of time
3. Press START (I) to crank engine

In the 'O' position the DC supply is removed from the module and the run output is de-energised.

The module is powered up when M is selected. Operation of the pre-heat button is only possible when in this position.

An LED tell-tale indicates pre-heat operation. Once the required pre-heat duration has elapsed, the pre-heat button should be released.

Once M is selected and the Start button is pressed and maintained, the engine fuel system is energised. The 'Crank' output is then energised and the starter motor operated, disengaging automatically when the engine fires or when the 'Start' button is released. The protection hold-off timer is then initiated.

Operation of any of the following alarms (which are close on fault) will cause the run output to de-energise:

- **Low Oil Pressure**
- **High Engine Temperature**
- **Auxiliary Shutdown**
- **Overspeed**

This will remove the fuel supply from the engine and bring it to rest.

Each alarm has its own LED indicator and once activated no further alarm conditions will be accepted. The alarm output and relevant LED will remain active until the unit is reset by turning the switch to the 'O' position.

Overspeed Protection

Overspeed protection is derived from the generator Hz output. The overfrequency circuit monitors the generator Hz output and will shut down the engine immediately if a pre-set frequency level is exceeded. This trip level is selected by a switch for either 50Hz or 60Hz nominal operation (57Hz and 68Hz trip respectively)

During engine cranking and for a short time afterwards the **protection hold-off timer (10 seconds)** is active and the relevant alarm inputs are inhibited. This enables the engine to start and achieve normal running conditions. Once the timer has expired the inputs are enabled providing normal protection from the module.

Charge Failure warning is also provided by monitoring the WL terminal on the charge alternator.

LCD Hours counter is incremented whenever the engine is running. The elapsed hours are displayed in all modes except the 'O' mode.



SPECIFICATION

DC Supply:

8 to 35 V Continuous.

Cranking Dropouts:

Able to survive voltage dips during cranking. *This is achieved without the need for internal batteries.*

Alternator Input Range:

15 - 305 V AC RMS (+20%)

Alternator Input Frequency:

50 - 60 Hz at rated engine speed.

(Minimum 75V AC)

Overspeed: nominal frequency +14% (+24% Overshoot)

Start Output:

Solid State 1.2A negative grounding terminal

Run Output:

Solid State 1.2A negative grounding terminal

Pre-heat Output:

Solid State 1.2A negative grounding terminal

Dimensions (Excluding Key-switch) :

84mm x 72mm x 34.9mm

(3.3" x 2.8" x 1.4")

Cut-out 80mm x 68mm (3.14" x 2.67")

Operating Temperature Range:

-30°C to +70°C

Installation:

Front panel mounting via suitable cut-out. Retaining clips supplied. Cable connections via screw clamp type terminals

Calibration:

Speed trip setting switch accessible from rear of module.

CASE DIMENSIONS

Imperial measurements
 Overall dimensions
 (excluding key)
 3.3" x 2.8" x 1.4"
 (protrudes 0.16" out of panel)
 Panel cutout
 3.0" x 2.6"

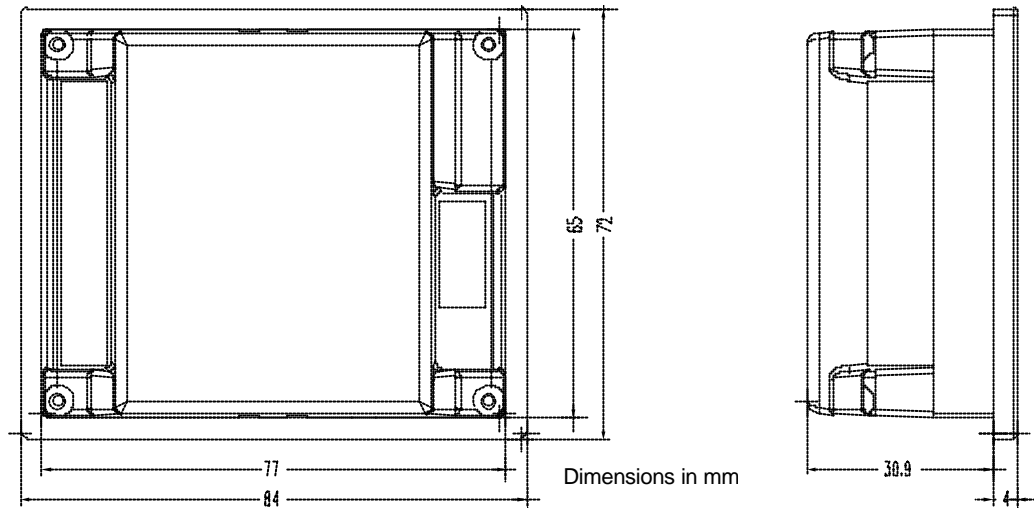

TYPICAL CONNECTIONS

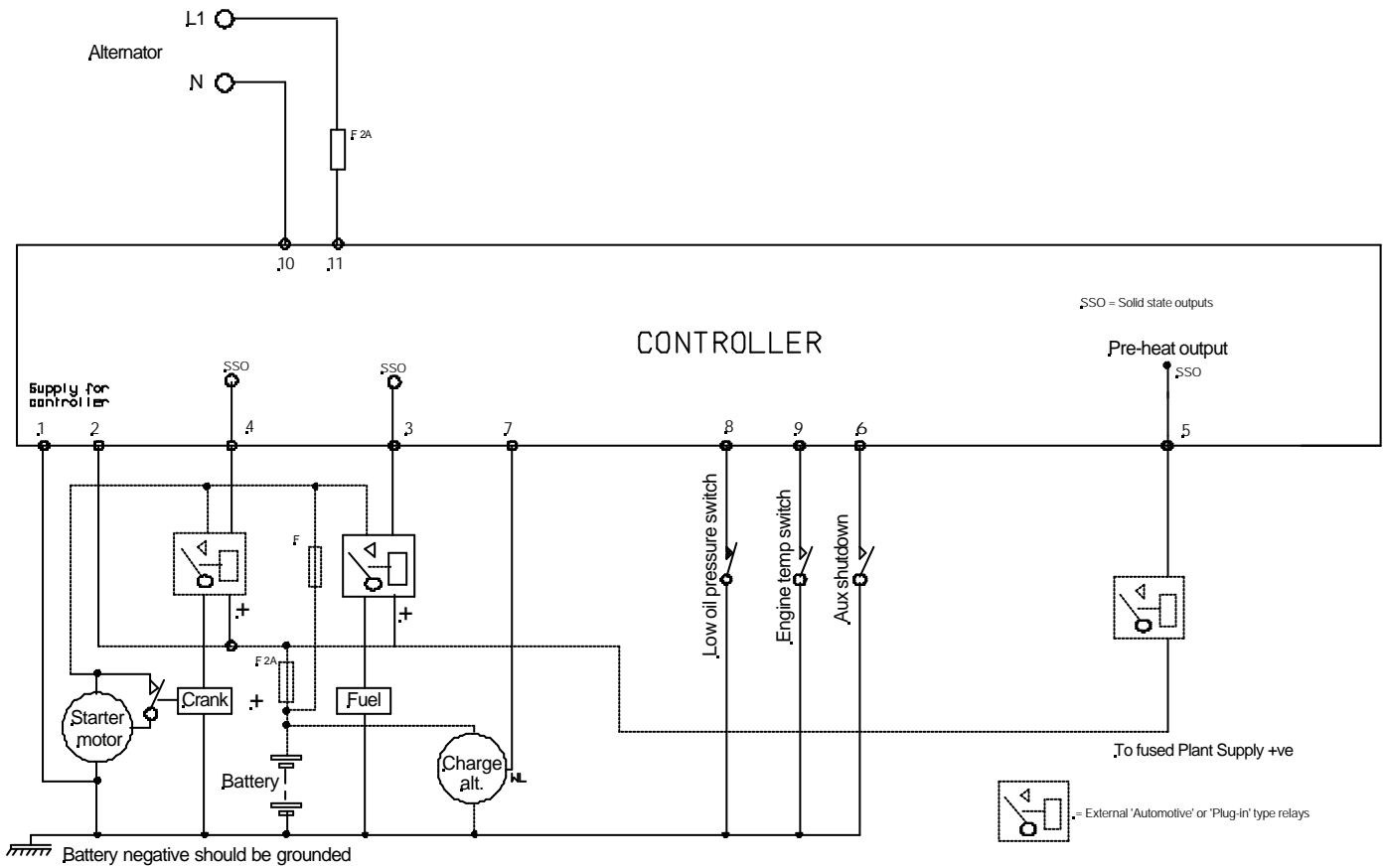

通達科技有限公司 Comprehensive Engineering Co., Ltd.

香港青衣長達路14至20號偉力工業大廈B座6樓2號室

Flat 2, 6/F, Block B, Vigor Industrial Building, 14-20 Cheung Tat Road, Tsing Yi, N.T. Hong Kong
 電話 Tel : +852 2435 2638 傳真 Fax : +852 2435 2666 電子郵箱 Email : cechk22@biznetvigator.com